



# SERIAL EEPROM

## Serial EEPROM Cross Reference Guide

The purpose of this document is to provide a quick way to determine the closest Microchip equivalent to Serial EEPROMs produced by other manufacturers. The cross reference section is broken down by manufacturer and lists all parts from that manufacturer, and the comparable Microchip part number. There is also a listing of manufacturer's part numbering schemes to assist in determining the specifications of a particular part.

There are subtle differences from manufacturer to manufacturer and device to device, so Microchip recommends consulting the respective manufacturer's gadabout for specific details.

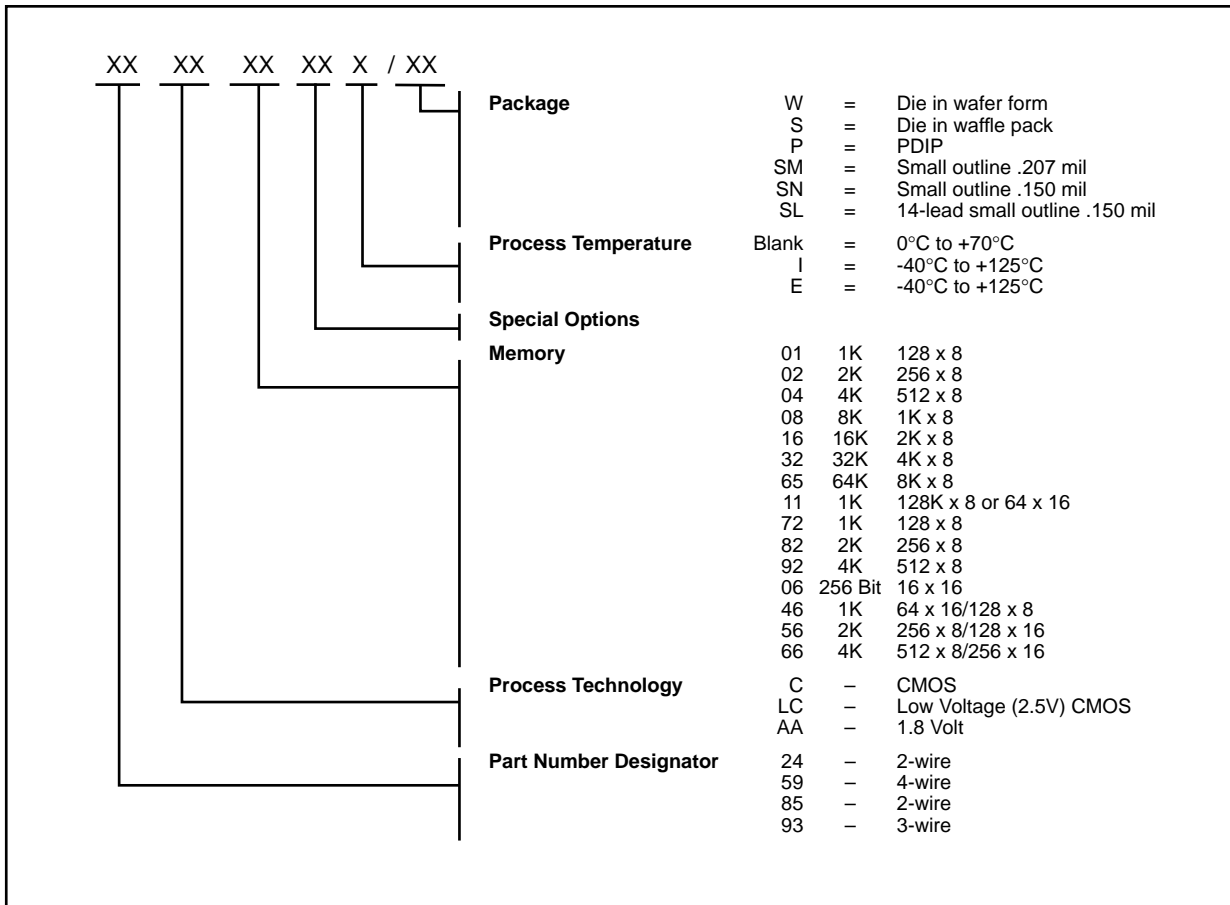
Microchip provides a wide selection of Serial EEPROM devices, both from a density and a packaging standpoint, as well as several different protocols. If you are

interested in a part that is not listed in this book, please refer to the Microchip data book, or contact your local distributor or sales representative for assistance.

The manufacturers\* included in this document are as follows:

AKM	Oki
Atmel	Philips
Catalyst	Samsung
Exel	SGS-Thomson
ISSI	Siemens
Microchip	Xicor
Mitsubishi	
National	

**FIGURE 1: MICROCHIP SERIAL EEPROM PART NUMBER GUIDE**



\*The above trademarks are property of their respective companies.

# SERIAL EEPROM

Manufacturer	Part Number	Closest Microchip Equivalent	Size
AKM	AK93C45	93C46	1K
AKM	AK93C45L	93C46	1K
AKM	AK93C55	93LC56	2K
AKM	AK93C55L	93AA56	2K
AKM	AK93C57	93LC56	2K
AKM	AK6420	93LC56	2K
AKM	AK93C65	93LC66	4K
AKM	AK93C65L	93AA66	4K
AKM	AK93C67	93LC66	4K
AKM	AK6420	93LC66	4K
ATMEL	AT24C01A	24LC01B/ 24C01A	1K
ATMEL	AT24C01A-2.7	24LC01B	1K
ATMEL	AT24C01A-2.5	24LC01B	1K
ATMEL	AT24C01A-1.8	24AA01	1K
ATMEL	AT59C11	59C11	1K
ATMEL	AT59C11-2.7	59C11	1K
ATMEL	AT59C11-2.5	59C11	1K
ATMEL	AT59C11-1.8	59C11	1K
ATMEL	AT93C46	93C46	1K
ATMEL	AT93C46-2.7	93LC46	1K
ATMEL	AT93C46-2.5	93LC46	1K
ATMEL	AT93C46-1.8	93LC46	1K
ATMEL	AT93C56	93LC56	2K
ATMEL	AT93C56-2.7	93LC56	2K
ATMEL	AT93C56-2.5	93LC56	2K
ATMEL	AT93C56-1.8	93AA56	2K
ATMEL	AT93C57	93LC56	2K
ATMEL	AT93C57-2.7	93LC56	2K
ATMEL	AT93C57-2.5	93LC56	2K
ATMEL	AT93C57-1.7	93AA56	2K
ATMEL	AT24C02	24C02/ 24LC02B	2K
ATMEL	AT24C02-2.7	24LC02B	2K
ATMEL	AT24C02-2.5	24LC02B	2K
ATMEL	AT24C02-1.8	24AA02	2K
ATMEL	AT93C66	93LC66	4K
ATMEL	AT93C66-2.7	93LC66	4K
ATMEL	AT93C66-2.5	93LC66	4K
ATMEL	AT93C66-1.8	93AA66	4K
ATMEL	AT24C04	24C04/ 24LC04B	4K
ATMEL	AT24C04-2.7	24LC04B	4K
ATMEL	AT24C04-2.5	24LC04B	4K
ATMEL	AT24C04-1.8	24AA04	4K
ATMEL	AT24C08	24LC08B	8K
ATMEL	AT24C08-2.7	24LC08B	8K
ATMEL	AT24C08-2.5	24LC08B	8K
ATMEL	AT24C08-1.8	24AA08	8K
ATMEL	AT24C16	24LC16B	16K
ATMEL	AT24C16-2.7	24LC16B	16K
ATMEL	AT24C16-2.5	24LC16B	16K
ATMEL	AT24C16-1.8	24AA16	16K
ATMEL	AT24C164	24LC164	16K
ATMEL	AT24C164-2.7	24LC164	16K
ATMEL	AT24C164-2.5	24LC164	16K
ATMEL	AT24C164-1.8	24AA164	16K
ATMEL	AT24C64	24C65*	64K
ATMEL	AT24C64-2.7	24C65*	64K
ATMEL	AT24C642.5	24C65*	64K

Manufacturer	Part Number	Closest Microchip Equivalent	Size
ATMEL	AT24C64-1.8	24C65*	64K
ATMEL	AT24C32	24C32*	32K
ATMEL	AT24C32-2.7	24C32*	32K
ATMEL	AT24C32-2.5	24C32*	32K
ATMEL	AT24C32-1.8	24C32*	32K
Catalyst	CAT59C11//A/A/H	59C11	1K
Catalyst	CAT33C101C/I	93LC46	1K
Catalyst	CAT33C101	93LC46	1K
Catalyst	CAT93C46//H	93LC46	1K
Catalyst	CAT93C46A//H	93LC46	1K
Catalyst	CAT35C102H/I	93LC56	2K
Catalyst	CAT93C56/I	93LC56	2K
Catalyst	CAT93LC56/I	93LC56	2K
Catalyst	CAT24C02/I	24C02B/ 24LC02B	2K
Catalyst	CAT24LC02/I	24LC02B	2K
Catalyst	CAT24C04.1	24C04A/ 24LC04B	4K
Catalyst	CAT24LC04.1	24LC04B	4K
Catalyst	CAT35C104/H/I	93LC66	4K
Catalyst	CAT33C104	93LC66	4K
Catalyst	CAT35C704/I	93LC66	4K
Catalyst	CAT33C704/I	93LC66	4K
Catalyst	CAT35C80	93LC66	4K
Catalyst	CAT33C80	93LC66	4K
Catalyst	CAT24C08	24LC08B	8K
Catalyst	CAT24LC08	24LC08B	8K
Catalyst	CAT24C16	24LC16B	16K
Catalyst	CAT24LC16	24LC16B	16K
Exel	XL93LC06	93C06	256bit
Exel	XL24C01A	24C01A/ 24LC01B	1K
Exel	XL24C01-2.5	24LC01B	1K
Exel	XL93CCSLC46	93C46	1K
Exel	XL93CCSLC46-3	93LC46	1K
Exel	XL24C01A-3	24LC01B	1K
Exel	XL24C02	24C02A/ 24LC02B	2K
Exel	XL24C02-3	24LC02B	2K
Exel	XL93C56,LC56	93LC56	2K
Exel	XL24C01-2.5	24LC01B	2K
Exel	XL93LC56-3	93LC56	2K
Exel	XL93C66,LC66	93LC66	4K
Exel	XL93C66-3,LC66-3	93LC66	4K
Exel	XL24C04	24C04A/ 24LC04B	4K
Exel	XL24C04-3	24LC04B	4K
Exel	XL24C04-2.5	24LC04B	4K
Exel	XL24C16	24LC16B	16K
Exel	XL24C16-3	24LC16B	16K
ISSI	IS93C46	93C46	1K
ISSI	IS93C46-3	93LC46	1K
ISSI	IS93C56	93LC56	2K
ISSI	IS93C66	93LC66	4K
National	NM93C06	93C06	256bit
National	NM93C46	93C46	1K
National	NM93C46LZ	93AA46	1K
National	NM93C56	93LC56	2K
National	NM93C56LZ	93AA56	2K
National	NM93CS56	93LCS56	2K

\*Not 100% compatible.

# SERIAL EEPROM

Manufacturer	Part Number	Closest Microchip Equivalent	Size
National	NM93CS56L	93LCS56	2K
National	NM24C02	24C02A/	2K
National	NM24C02L	24LC02B	2K
National	NM24C03	24C02A	2K
National	NM24C03L	24LC02B	2K
National	NM93C66	93LC66	4K
National	NM93CS66	93LCS66	4K
National	NM93C66L	93LC66	4K
National	NM93CS66L	93LCS66	4K
National	NM93C66LZ	93AA66	4K
National	NM24C04	24C04A/ 24LC04B	4K
National	NM24C04L	24LC04B	4K
National	NM24C05L	24LC04B	4K
National	NM24C08	24LC08B	8K
National	NM24C08L	24LC08B	8K
National	NM24C09	24LC08B	8K
National	NM24C09L	24LC08B	8K
National	NM24C16	24LC16B	16K
National	NM24C16L	24LC16B	16K
National	NM24C17	24LC16B	16K
National	NM24C17L	24LC16B	16K
Oki	MSM16812	93LC56	2K
Philips-Signetics	PCA8581	24C01A	1K
Philips-Signetics	PCF8582C2	85C82	2K
Philips-Signetics	PCD8582D2	85C82	2K
Philips-Signetics	PCF8582F2	85C82	2K
Philips-Signetics	PCF8594C-2	24AA04	4K
Philips-Signetics	PCD8594D-2	24LC04B	4K
Philips-Signetics	PCF8598C-2	24LC08B	8K
Philips-Signetics	PCD8598D-2	24LC08B	8K
Philips-Signetics	PCD8598F-2	24LC08B	8K
Samsung	KM93C06	93C06256bit	
Samsung	KM93C07	93C06256bit	
Samsung	KM93C46	93C46	1K
Samsung	KM94C46V	93C46	1K
Samsung	KM93C56	93LC56	2K
Samsung	KM93CS56	93LCS56	2K
Samsung	KM93C56V	93AA56	2K
Samsung	KM93C57	93LC56	2K
Samsung	KM93C57V	93AA56	2K
Samsung	KM93C66	93LC66	4K
Samsung	KM93CS66	93LCS66	4K
Samsung	KM93C66V	93AA66	4K
Samsung	KM93C67	93LC66	4K
Samsung	KM93C67V	93AA66	4K
SEEQ	2913A	93C46	1K
SEEQ	2913C	93C46	1K
SEEQ	2914A	93C46	1K
SEEQ	2919G	93C46	1K
SEEQ	2922A	93LC56	2K
SEEQ	2929G	93LC56	2K

Manufacturer	Part Number	Closest Microchip Equivalent	Size
SEEQ	2934A	93LC66	4K
SEEQ	2929G	93LC66	4K
SGS-Thomson	ST93C06	93C06	256bit
SGS-Thomson	ST24C01	24LC01B	1K
SGS-Thomson	ST93C46A	93C46	1K
SGS-Thomson	ST93C46T	93C46	1K
SGS-Thomson	ST93C46	93LC46	1K
SGS-Thomson	ST24W01	24LC01B	1K
SGS-Thomson	ST25W01	24LC01B	1K
SGS-Thomson	ST93C56	93LC56	2K
SGS-Thomson	ST93CS56	93LCS56	2K
SGS-Thomson	ST93CS57	93LCS56	2K
SGS-Thomson	ST24C02A	24LC02B	2K
SGS-Thomson	ST24C02C	24LC02B	2K
SGS-Thomson	ST24W02C	24LC02B	2K
SGS-Thomson	ST25C02A	24LC02B	2K
SGS-Thomson	ST25W02C	24LC02B	2K
SGS-Thomson	ST93CS66	93LCS66	4K
SGS-Thomson	ST93CS67	93LCS66	4K
SGS-Thomson	ST24C04	24C04A/ 24LC04B/	4K
SGS-Thomson	ST24C04C	24LC04B	4K
SGS-Thomson	ST24W04C	24LC04B	4K
SGS-Thomson	ST25C04	24LC04B	4K
SGS-Thomson	ST25C0RC	24LC04B	4K
SGS-Thomson	ST25W04C	24LC04B	4K
SGS-Thomson	ST24C08	24LC08B	8K
SGS-Thomson	ST24C08C	24LC08B	8K
SGS-Thomson	ST25C08C	24LC08B	8K
SGS-Thomson	ST24C16C	24LC16B	16K
SGS-Thomson	ST24E16C	24LC16B	16K
SGS-Thomson	ST25C16C	24LC16B	16K
SGS-Thomson	ST25E16C	24LC16B	16K
SGS-Thomson	ST24E32D	24LC32*	32K
SGS-Thomson	ST25E32D	24LC32*	32K
SGS-Thomson	ST24E64D	24LC65*	64K
SGS-Thomson	ST25E64D	24LC65*	64K
Siemens	SDA2516-2	24C01A/ 24LC01B	1K
Siemens	SDA2526-2	24C02A/ 24LC02B	2K
Siemens	SDA2546	24C04A/ 24LC04B	4K
Siemens	SDA2586	24LC08B	8K
Xicor	X24C01A	24LC01B	1K
Xicor	X2402	24C02A	2K
Xicor	X24C02	24LC02B	2K
Xicor	X2404	24C04A/ 24LC04B	4K
Xicor	X24C04	24LC04B	4K
Xicor	X24C08	24LC08B	8K
Xicor	X24C16	24LC16B	16K
Xicor	X24164	24LC164	16K
Xicor	X24645	24LC65*	64K

\*Not 100% compatible.

# SERIAL EEPROM

## COMPETITIVE PART NUMBER BREAKDOWN

FIGURE 2: ATMEL

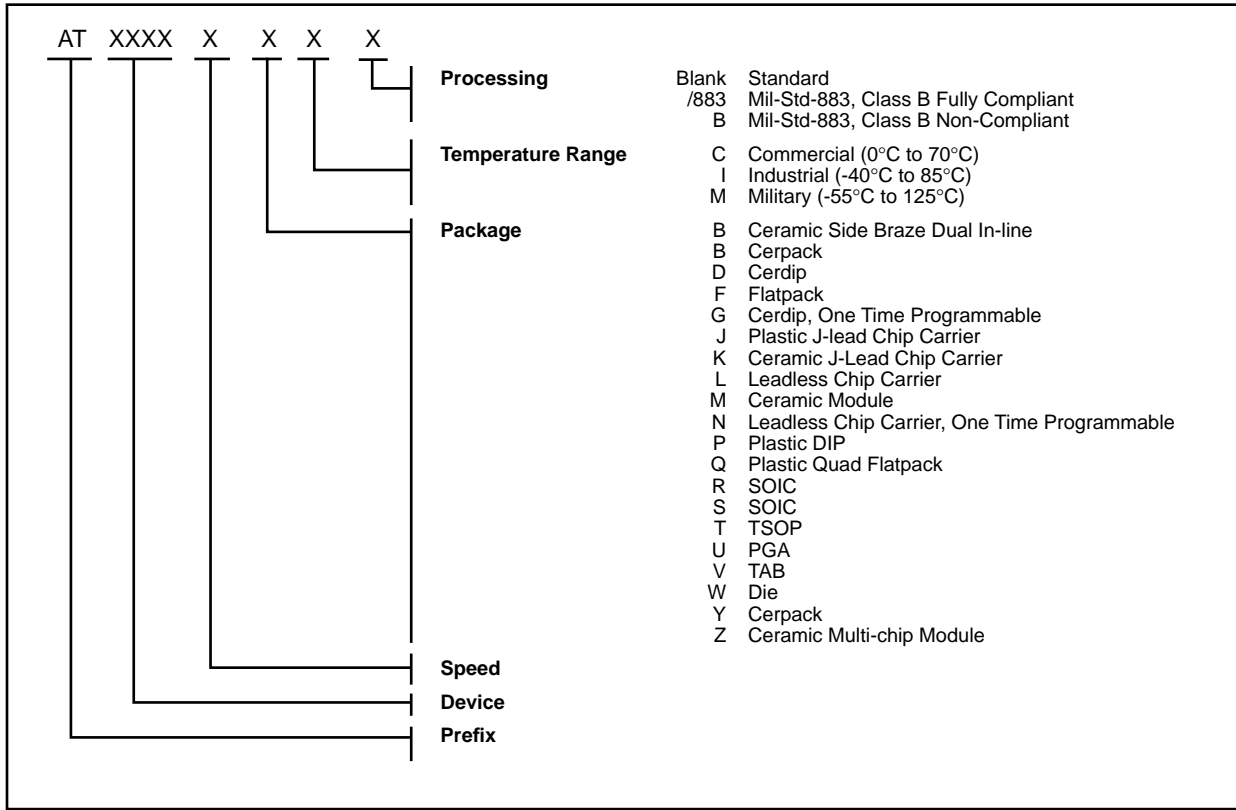
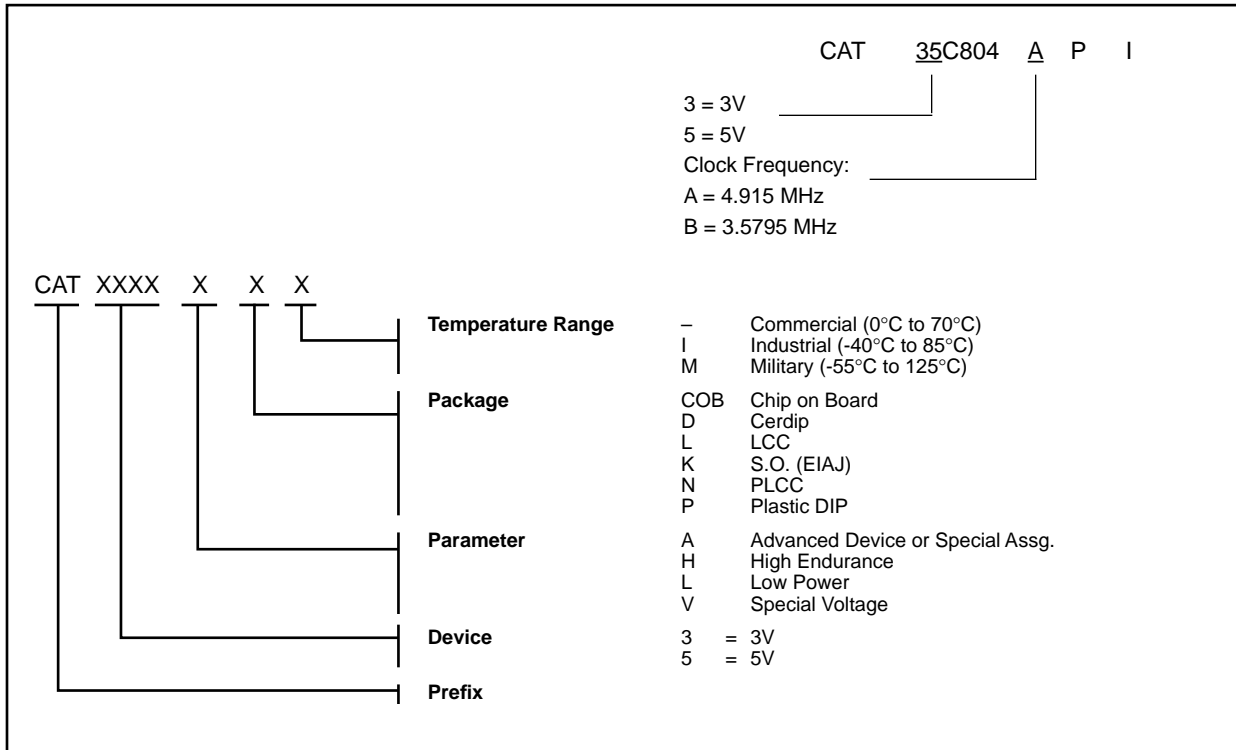
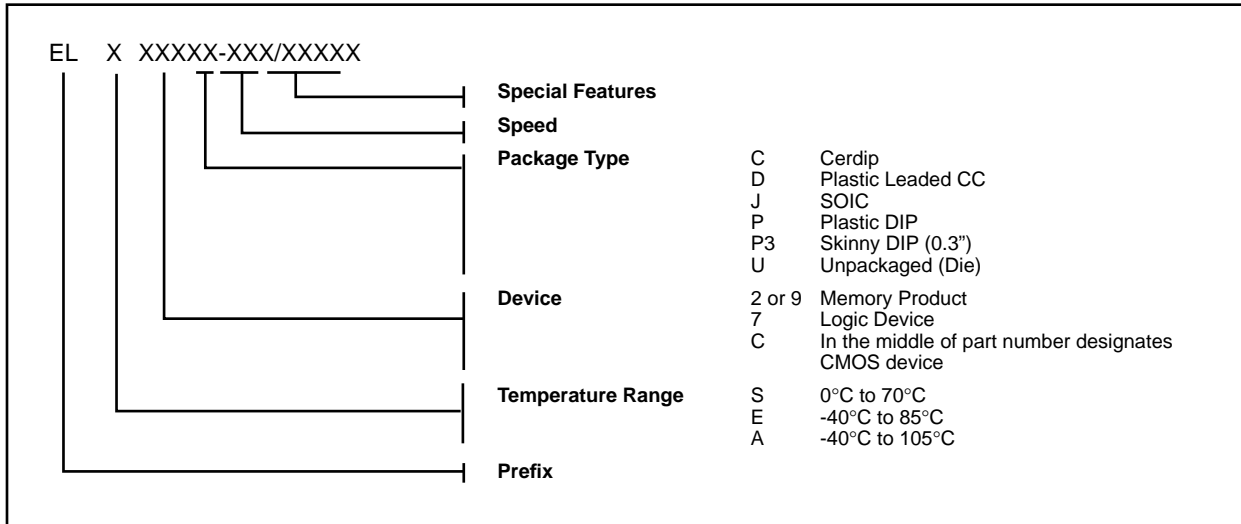


FIGURE 3: CATALYST SEMICONDUCTOR

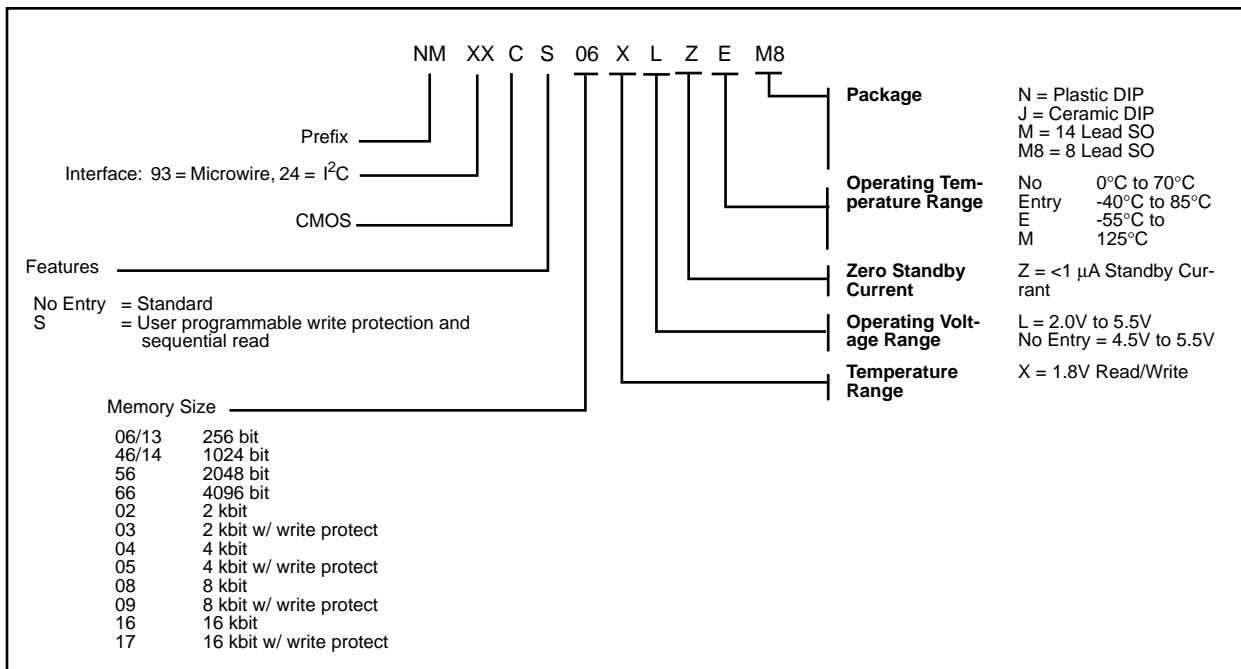


# SERIAL EEPROM

**FIGURE 4: EXEL**

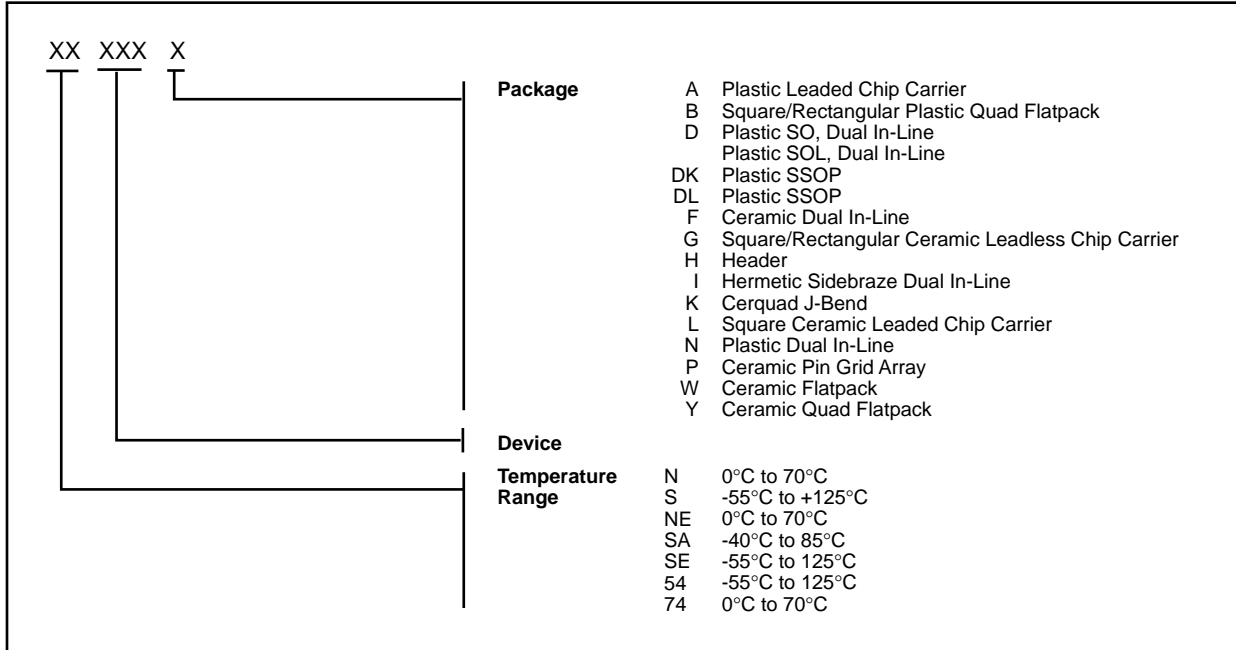


**FIGURE 5: NATIONAL SEMICONDUCTOR CORPORATION**

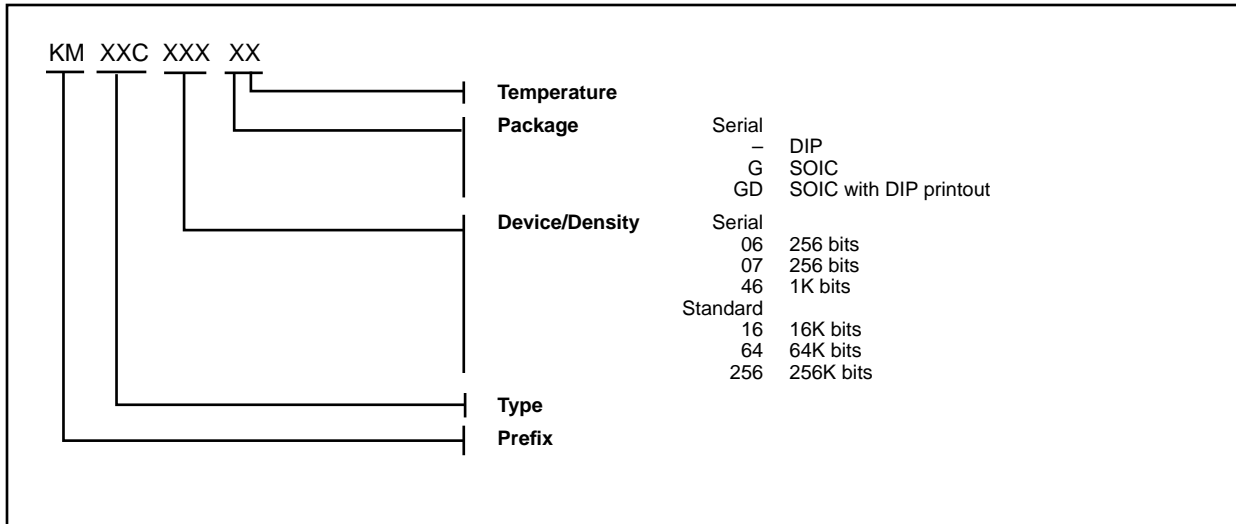


# SERIAL EEPROM

**FIGURE 6: PHILIPS**

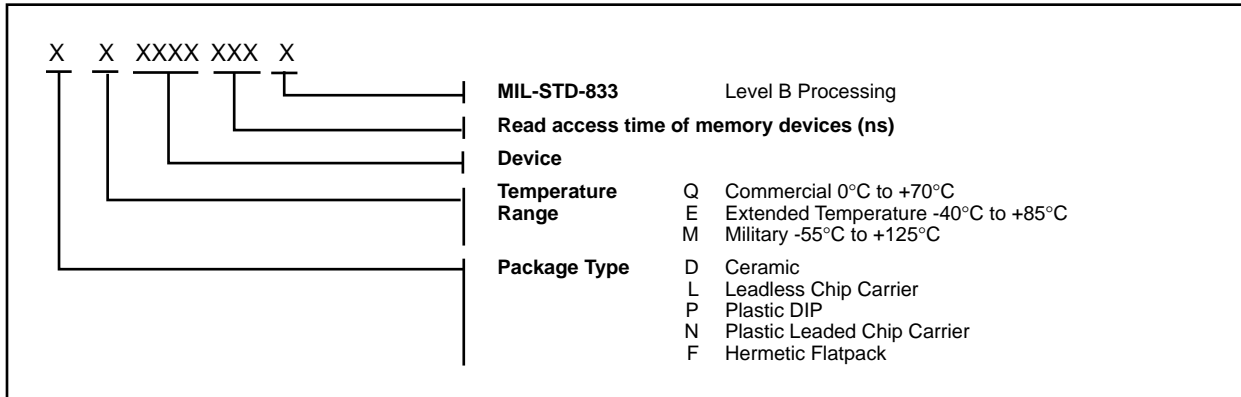


**FIGURE 7: SAMSUNG**

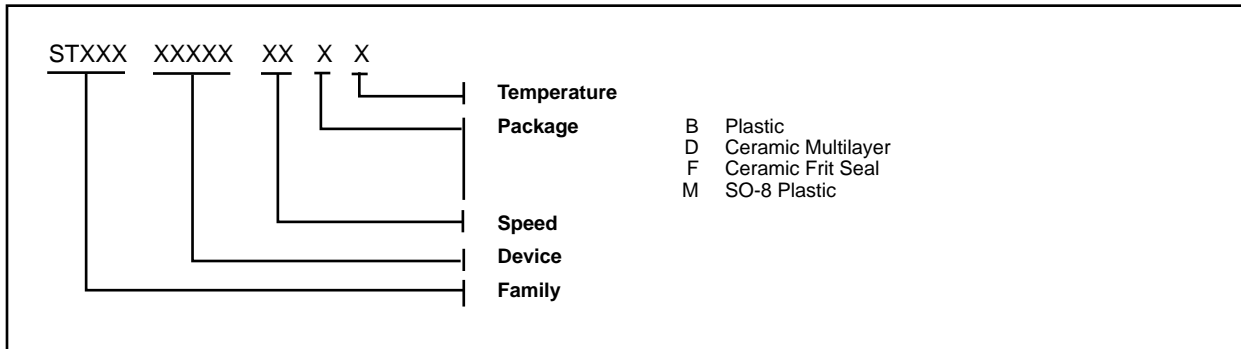


# SERIAL EEPROM

**FIGURE 8: SEEQ**

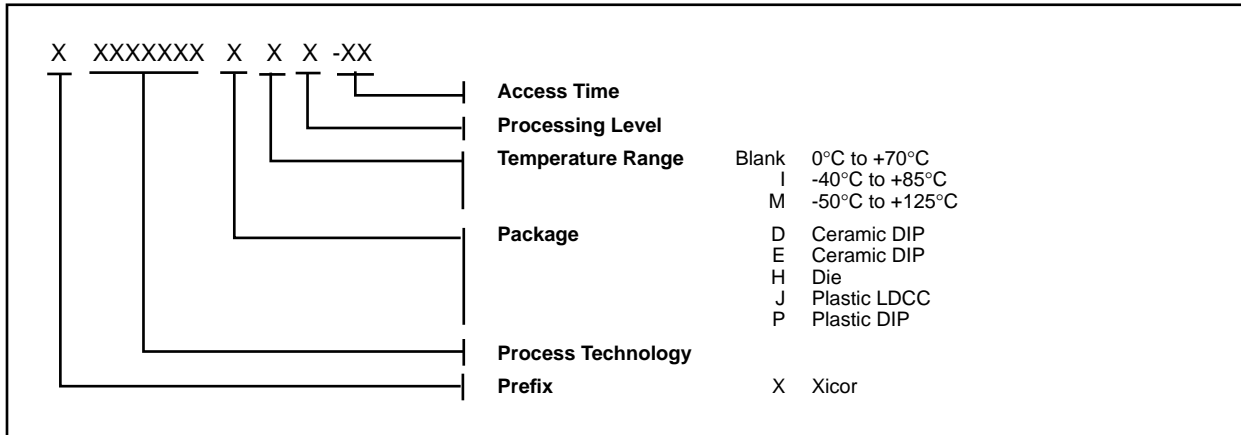


**FIGURE 9: SGS-THOMSON**



**FIGURE 10: SIEMENS - NOT AVAILABLE**

**FIGURE 11: XICOR**



# SERIAL EEPROM

---

---

NOTES