

Undervoltage Sensing Circuit

The MC34064 is an undervoltage sensing circuit specifically designed for use as a reset controller in microprocessor-based systems. It offers the designer an economical solution for low voltage detection with a single external resistor. The MC34064 features a trimmed-in-package bandgap reference, and a comparator with precise thresholds and built-in hysteresis to prevent erratic reset operation. The open collector reset output is capable of sinking in excess of 10 mA, and operation is guaranteed down to 1.0 V input with low standby current. These devices are packaged in 3-pin TO-226AA, 8-pin SO-8 and Micro-8 surface mount packages.

Applications include direct monitoring of the 5.0 V MPU/logic power supply used in appliance, automotive, consumer and industrial equipment.

- Trimmed-In-Package Temperature Compensated Reference
- Comparator Threshold of 4.6 V at 25°C
- Precise Comparator Thresholds Guaranteed Over Temperature
- Comparator Hysteresis Prevents Erratic Reset
- Reset Output Capable of Sinking in Excess of 10 mA
- Internal Clamp Diode for Discharging Delay Capacitor
- Guaranteed Reset Operation with 1.0 V Input
- Low Standby Current
- Economical TO-226AA, SO-8 and Micro-8 Surface Mount Packages

Representative Block Diagram

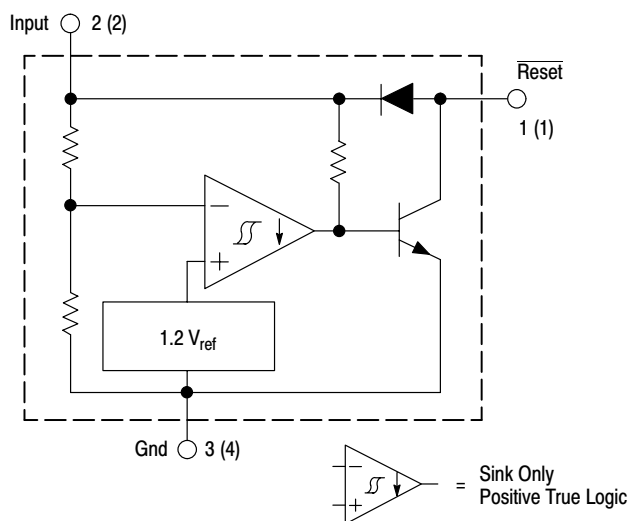

Pin numbers adjacent to terminals are for the 3-pin TO-226AA package. Pin numbers in parenthesis are for the 8-lead packages.

This device contains 21 active transistors.

MC34064 MC33064

UNDERVOLTAGE SENSING CIRCUIT

SEMICONDUCTOR TECHNICAL DATA

P SUFFIX
PLASTIC PACKAGE
CASE 29
(TO-226AA)

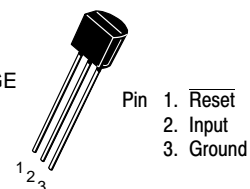

D SUFFIX
PLASTIC PACKAGE
CASE 751
(SO-8)



DM SUFFIX
PLASTIC PACKAGE
CASE 846A
(Micro-8)

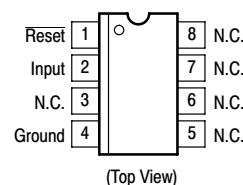

ORDERING INFORMATION

Device	Operating Temperature Range	Package
MC34064D-5	$T_A = 0^\circ \text{ to } +70^\circ\text{C}$	SO-8
MC34064DM-5		Micro-8
MC34064P-5		TO-226AA
MC33064D-5	$T_A = -40^\circ \text{ to } +85^\circ\text{C}$	SO-8
MC33064DM-5		Micro-8
MC33064P-5		TO-226AA

MC34064 MC33064

MAXIMUM RATINGS

Rating	Symbol	Value	Unit
Power Input Supply Voltage	V_{in}	-1.0 to 10	V
Reset Output Voltage	V_O	10	V
Reset Output Sink Current (Note 1)	I_{Sink}	Internally Limited	mA
Clamp Diode Forward Current, Pin 1 to 2 (Note 1)	I_F	100	mA
Power Dissipation and Thermal Characteristics			
P Suffix, Plastic Package			
Maximum Power Dissipation @ $T_A = 25^\circ\text{C}$	P_D	625	mW
Thermal Resistance, Junction-to-Air	$R_{\theta JA}$	200	$^\circ\text{C/W}$
D Suffix, Plastic Package			
Maximum Power Dissipation @ $T_A = 25^\circ\text{C}$	P_D	625	mW
Thermal Resistance, Junction-to-Air	$R_{\theta JA}$	200	$^\circ\text{C/W}$
DM Suffix, Plastic Package			
Maximum Power Dissipation @ $T_A = 25^\circ\text{C}$	P_D	520	mW
Thermal Resistance, Junction-to-Air	$R_{\theta JA}$	240	$^\circ\text{C/W}$
Operating Junction Temperature	T_J	+150	$^\circ\text{C}$
Operating Ambient Temperature	T_A		$^\circ\text{C}$
MC34064		0 to +70	
MC33064		-40 to +85	
Storage Temperature Range	T_{stg}	-65 to +150	$^\circ\text{C}$

NOTE: ESD data available upon request.

ELECTRICAL CHARACTERISTICS (For typical values $T_A = 25^\circ\text{C}$, for min/max values T_A is the operating ambient temperature range that applies [Notes 2 and 3] unless otherwise noted.)

Characteristics	Symbol	Min	Typ	Max	Unit
COMPARATOR					
Threshold Voltage					V
High State Output (V_{in} Increasing)	V_{IH}	4.5	4.61	4.7	
Low State Output (V_{in} Decreasing)	V_{IL}	4.5	4.59	4.7	
Hysteresis	V_H	0.01	0.02	0.05	

RESET OUTPUT

Output Sink Saturation	V_{OL}				V
($V_{in} = 4.0\text{ V}$, $I_{Sink} = 8.0\text{ mA}$)		-	0.46	1.0	
($V_{in} = 4.0\text{ V}$, $I_{Sink} = 2.0\text{ mA}$)		-	0.15	0.4	
($V_{in} = 1.0\text{ V}$, $I_{Sink} = 0.1\text{ mA}$)		-	-	0.1	
Output Sink Current (V_{in} , $\overline{\text{Reset}} = 4.0\text{ V}$)	I_{Sink}	10	27	60	mA
Output Off-State Leakage (V_{in} , $\overline{\text{Reset}} = 5.0\text{ V}$)	I_{OH}	-	0.02	0.5	μA
Clamp Diode Forward Voltage, Pin 1 to 2 ($I_F = 10\text{ mA}$)	V_F	0.6	0.9	1.2	V

TOTAL DEVICE

Operating Input Voltage Range	V_{in}	1.0 to 6.5	-	-	V
Quiescent Input Current ($V_{in} = 5.0\text{ V}$)	I_{in}	-	390	500	μA

- NOTES:**
- Maximum package power dissipation limits must be observed.
 - Low duty cycle pulse techniques are used during test to maintain junction temperature as close to ambient as possible.
 - $T_{low} = 0^\circ\text{C}$ for MC34064
 $T_{high} = +70^\circ\text{C}$ for MC34064
 -40°C for MC33064
 $+85^\circ\text{C}$ for MC33064

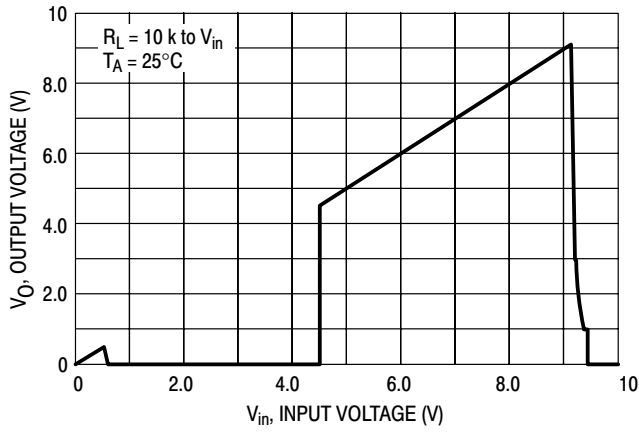

Figure 1. Reset Output Voltage versus Input Voltage

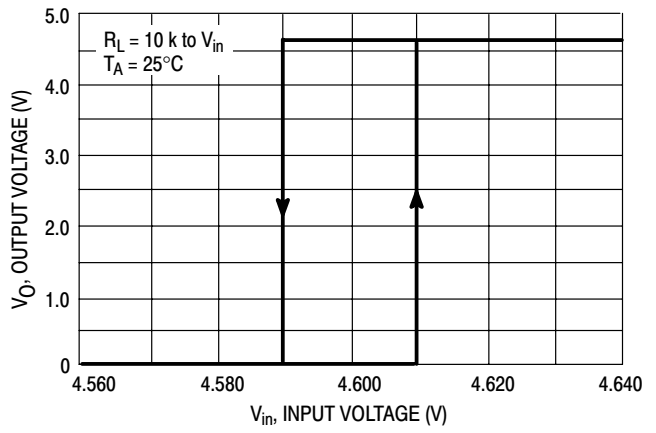

Figure 2. Reset Output Voltage versus Input Voltage

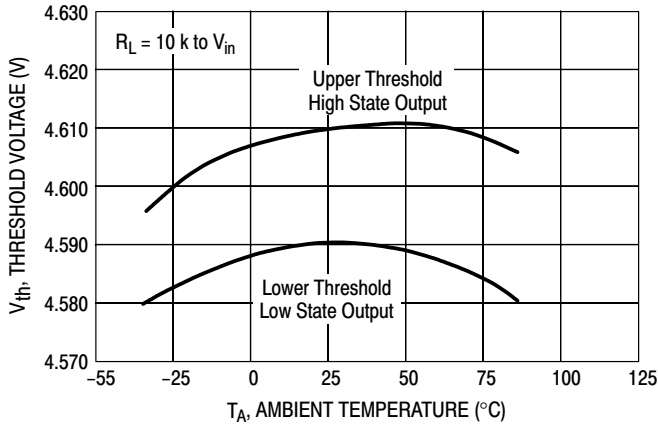

Figure 3. Comparator Threshold Voltage versus Temperature

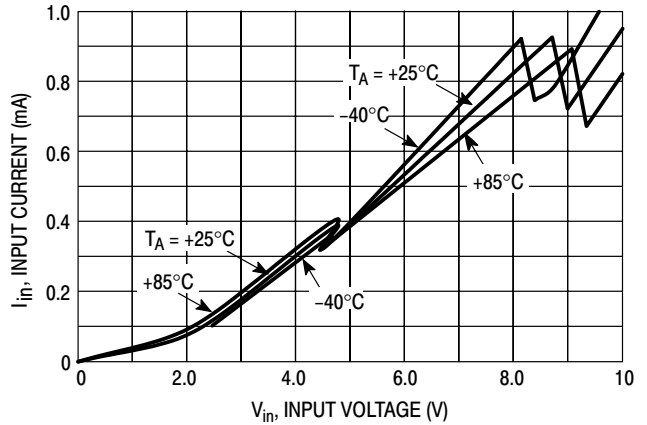

Figure 4. Input Current versus Input Voltage

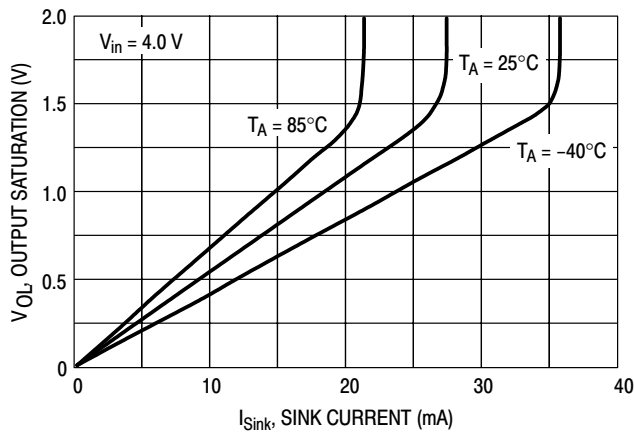

Figure 5. Reset Output Saturation versus Sink Current

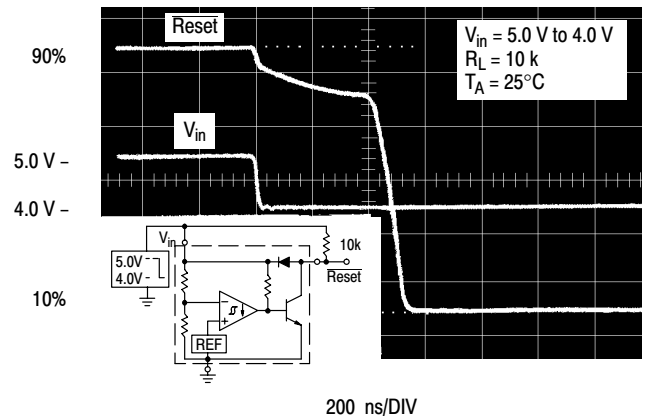

Figure 6. Reset Delay Time

MC34064 MC33064

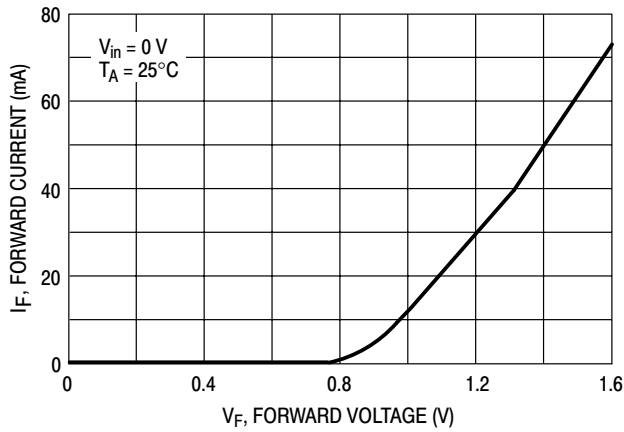

Figure 7. Clamp Diode Forward Current versus Voltage

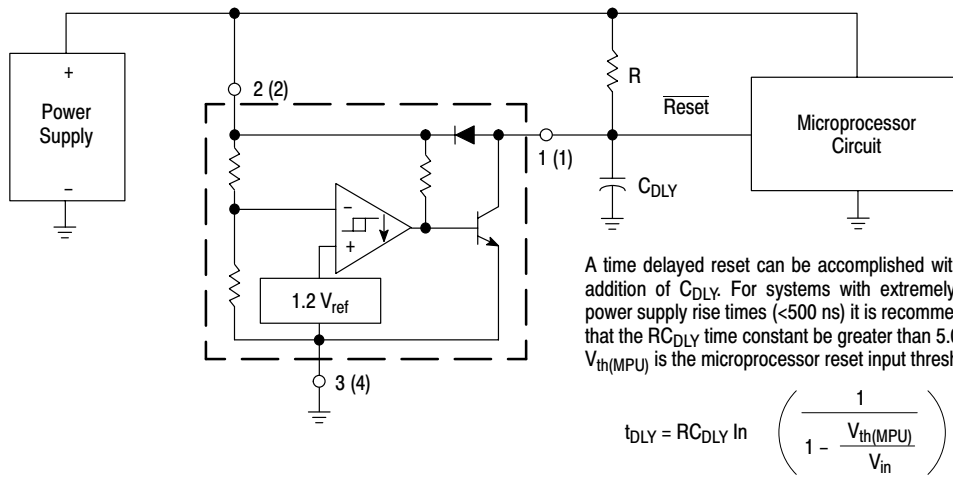

Figure 8. Low Voltage Microprocessor Reset

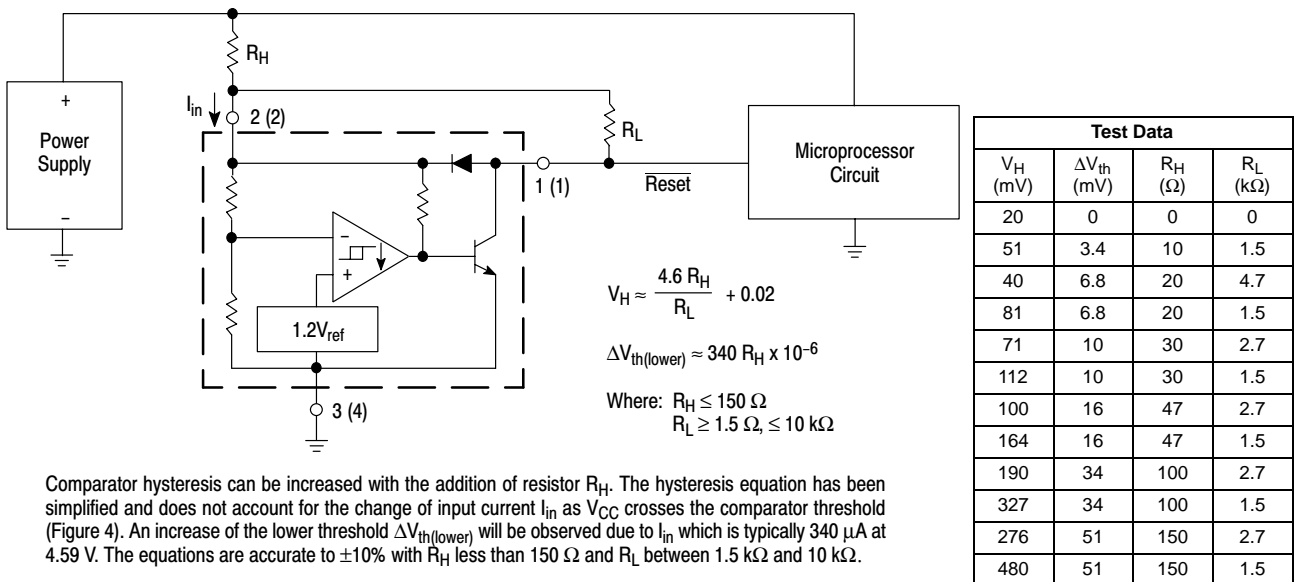

Figure 9. Low Voltage Microprocessor Reset with Additional Hysteresis

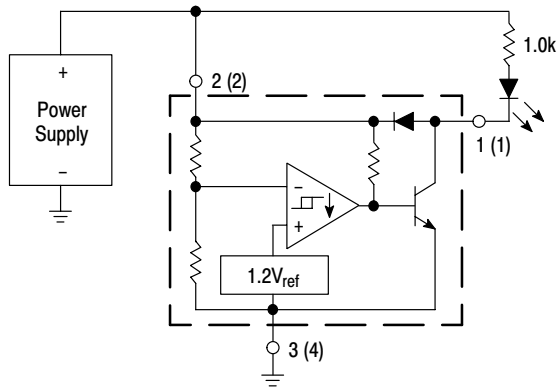

Figure 10. Voltage Monitor

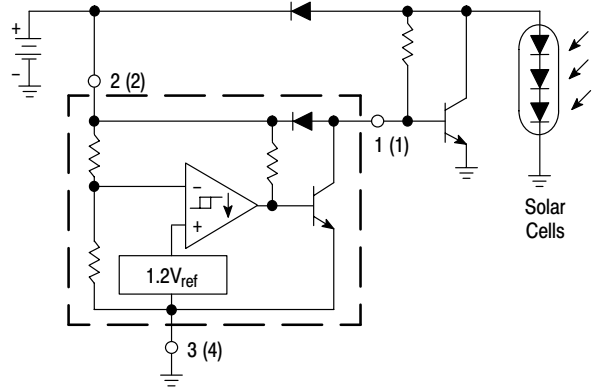
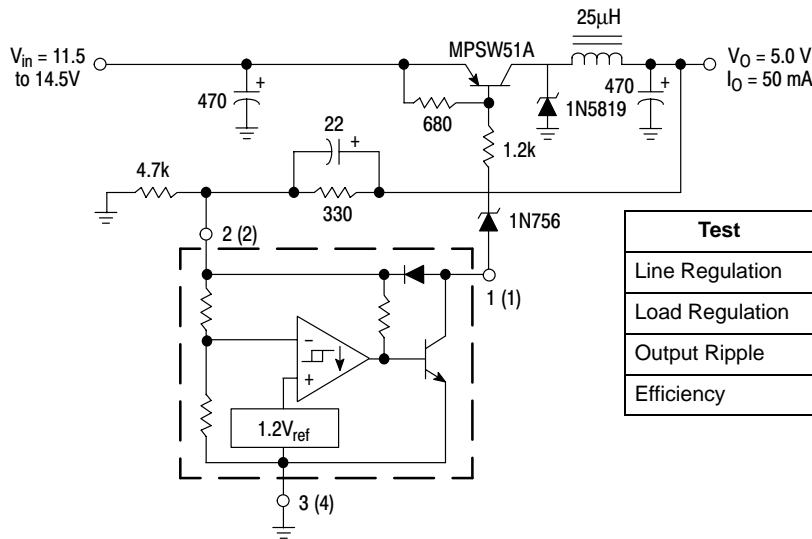
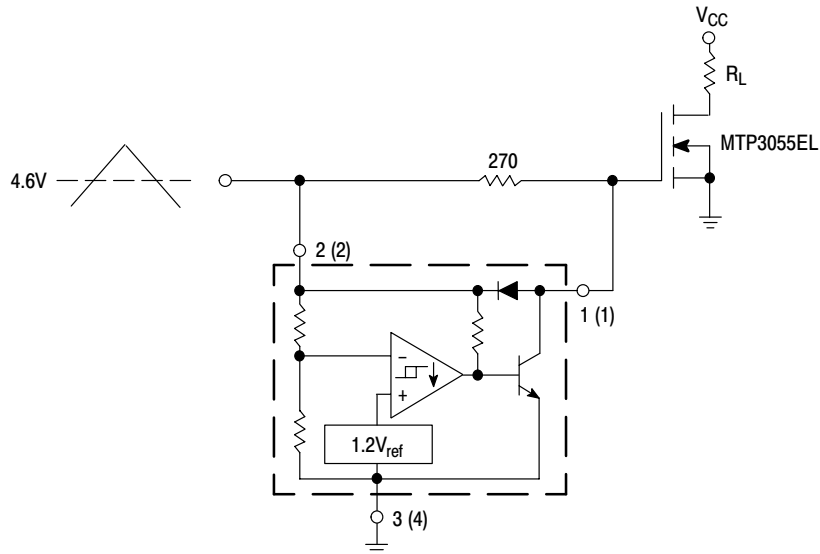

Figure 11. Solar Powered Battery Charger



Test	Conditions	Results
Line Regulation	$V_{in} = 11.5 \text{ V to } 14.5 \text{ V}, I_O = 50 \text{ mA}$	35 mV
Load Regulation	$V_{in} = 12.6 \text{ V}, I_O = 0 \text{ mA to } 50 \text{ mA}$	12 mV
Output Ripple	$V_{in} = 12.6 \text{ V}, I_O = 50 \text{ mA}$	60 mVpp
Efficiency	$V_{in} = 12.6 \text{ V}, I_O = 50 \text{ mA}$	77%

Figure 12. Low Power Switching Regulator



Overheating of the logic level power MOSFET due to insufficient gate voltage can be prevented with the above circuit. When the input signal is below the 4.6 V threshold of the MC34064, its output grounds the gate of the L² MOSFET.

Figure 13. MOSFET Low Voltage Gate Drive Protection

MC34064 MC33064

PACKAGE DIMENSIONS

DM SUFFIX
 PLASTIC PACKAGE
 CASE 846A-02
 (Micro-8)
 ISSUE E

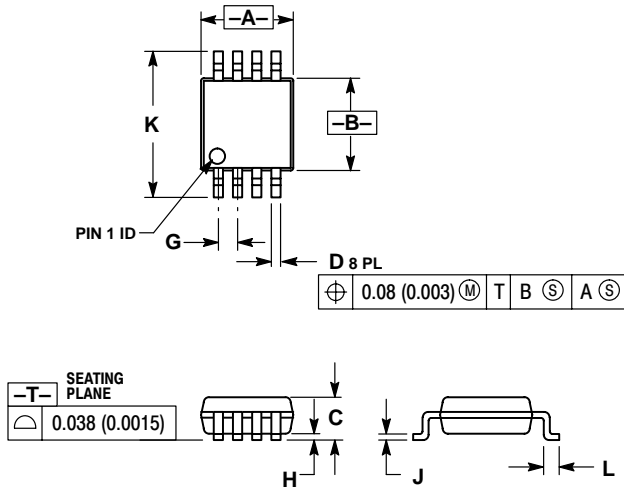

NOTES:

1. DIMENSIONING AND TOLERANCING PER ANSI Y14.5M, 1982.
2. CONTROLLING DIMENSION: MILLIMETER.
3. DIMENSION A DOES NOT INCLUDE MOLD FLASH, PROTRUSIONS OR GATE BURRS. MOLD FLASH, PROTRUSIONS OR GATE BURRS SHALL NOT EXCEED 0.15 (0.006) PER SIDE.
4. DIMENSION B DOES NOT INCLUDE INTERLEAD FLASH OR PROTRUSION. INTERLEAD FLASH OR PROTRUSION SHALL NOT EXCEED 0.25 (0.010) PER SIDE.

		MILLIMETERS		INCHES	
DIM		MIN	MAX	MIN	MAX
A		2.90	3.10	0.114	0.122
B		2.90	3.10	0.114	0.122
C		---	1.10	---	0.043
D		0.25	0.40	0.010	0.016
G		0.65 BSC		0.026 BSC	
H		0.05	0.15	0.002	0.006
J		0.13	0.23	0.005	0.009
K		4.75	5.05	0.187	0.199
L		0.40	0.70	0.016	0.028

ON Semiconductor and  are trademarks of Semiconductor Components Industries, LLC (SCILLC). SCILLC reserves the right to make changes without further notice to any products herein. SCILLC makes no warranty, representation or guarantee regarding the suitability of its products for any particular purpose, nor does SCILLC assume any liability arising out of the application or use of any product or circuit, and specifically disclaims any and all liability, including without limitation special, consequential or incidental damages. "Typical" parameters which may be provided in SCILLC data sheets and/or specifications can and do vary in different applications and actual performance may vary over time. All operating parameters, including "Typicals" must be validated for each customer application by customer's technical experts. SCILLC does not convey any license under its patent rights nor the rights of others. SCILLC products are not designed, intended, or authorized for use as components in systems intended for surgical implant into the body, or other applications intended to support or sustain life, or for any other application in which the failure of the SCILLC product could create a situation where personal injury or death may occur. Should Buyer purchase or use SCILLC products for any such unintended or unauthorized application, Buyer shall indemnify and hold SCILLC and its officers, employees, subsidiaries, affiliates, and distributors harmless against all claims, costs, damages, and expenses, and reasonable attorney fees arising out of, directly or indirectly, any claim of personal injury or death associated with such unintended or unauthorized use, even if such claim alleges that SCILLC was negligent regarding the design or manufacture of the part. SCILLC is an Equal Opportunity/Affirmative Action Employer.

PUBLICATION ORDERING INFORMATION

NORTH AMERICA Literature Fulfillment:

Literature Distribution Center for ON Semiconductor
P.O. Box 5163, Denver, Colorado 80217 USA
Phone: 303-675-2175 or 800-344-3860 Toll Free USA/Canada
Fax: 303-675-2176 or 800-344-3867 Toll Free USA/Canada
Email: ONlit@hibbertco.com
Fax Response Line: 303-675-2167 or 800-344-3810 Toll Free USA/Canada

N. American Technical Support: 800-282-9855 Toll Free USA/Canada

EUROPE: LDC for ON Semiconductor – European Support

German Phone: (+1) 303-308-7140 (Mon-Fri 2:30pm to 7:00pm CET)
Email: ONlit-german@hibbertco.com
French Phone: (+1) 303-308-7141 (Mon-Fri 2:00pm to 7:00pm CET)
Email: ONlit-french@hibbertco.com
English Phone: (+1) 303-308-7142 (Mon-Fri 12:00pm to 5:00pm GMT)
Email: ONlit@hibbertco.com

EUROPEAN TOLL-FREE ACCESS*: 00-800-4422-3781

*Available from Germany, France, Italy, UK, Ireland

CENTRAL/SOUTH AMERICA:

Spanish Phone: 303-308-7143 (Mon-Fri 8:00am to 5:00pm MST)
Email: ONlit-spanish@hibbertco.com
Toll-Free from Mexico: Dial 01-800-288-2872 for Access –
then Dial 866-297-9322

ASIA/PACIFIC: LDC for ON Semiconductor – Asia Support

Phone: 1-303-675-2121 (Tue-Fri 9:00am to 1:00pm, Hong Kong Time)
Toll Free from Hong Kong & Singapore:
001-800-4422-3781
Email: ONlit-asia@hibbertco.com

JAPAN: ON Semiconductor, Japan Customer Focus Center
4-32-1 Nishi-Gotanda, Shinagawa-ku, Tokyo, Japan 141-0031
Phone: 81-3-5740-2700
Email: r14525@onsemi.com

ON Semiconductor Website: <http://onsemi.com>

For additional information, please contact your local Sales Representative.